

## Phasing procedure for Rod Metering Pumps (RMP)

“Phasing” is a term used to describe the adjustment of pressures at the start of dispensing a dual component adhesive. Commonly, material viscosities, rheologies, compressibility etc. are quite different. When these different components are forced under pressure into a mixing chamber, whether it is a static mix tube or a dynamic spinning mixer, these materials may behave differently at the beginning of each cycle. Sometimes one material may need to be pre-compressed to a certain degree to allow it to start out “on ratio” and blend with the other component.

**Note: Before attempting to phase the machine, make sure main pressure seals and check valves are operating properly, see “pressure seal/check valve” test procedure in the manual.**

In a rod metering pump (RMP), each rod, (fig 2, #8) is simultaneously pushed into a pump housing. At rest, (or “home position”), (fig 2, #1) these rods are typically about 1-1/2” from the main pressure seal. After traveling the 1-1/2” “recharge distance” the rods begin to come in contact with the main pressure seal, sealing off the inlet. At this point the uni-directionally operated, (double hinged) roller valve, (fig 2, #2) is actuated, thus sending a signal for the dispense valve to open. Also, this point is where the “phasing” will need to be done. If two materials were identical, phasing would be accomplished by making sure both metering rods are adjusted the same, (coming in contact with the seal at the same time). This also may be witnessed by watching the outlet fluid pressure gauges while dispensing, both pressures should start to rise together. If one side lags, this would indicate compressibility in the pump. This compressibility may be a matter of a small air pocket trapped in the top of the “pressure tube”. The air pocket can be eliminated by opening the bleed valve at the top of the pressure tube. If this is not the case, one material is probably more compressible than the other and the rod of the pump that is more compressible will need to be adjusted inward. This will make one rod come in contact with the pressure seal first and “pre-compress” the material. The following is the step by step procedure for accomplishing this.

1. Bleed both pumps.
  - 1.1. Open the bleed valve, (fig 1, #1) on the top of each pressure tube until a steady, air-free stream of material flows from the small port in the valve.
  - 1.2. Turn the machine speed down, (usually by turning the main air pressure regulator down), (fig 3, #1).
  - 1.3. On higher viscosity materials, it may be necessary to slowly cycle the machine forward while the bleed valve is open.
    - 1.3.1. Make sure the bleed valve is closed again before the pump rods reverse direction. If this is not done, air will be pulled back into the pressure tube on the return stroke. (It may be easiest to simply disconnect the air from the

machine, (fig 3, #3) at the end of the stroke to ensure the bleed valve is closed prior to the rods retracting.)

1.4. Repeat for both materials.

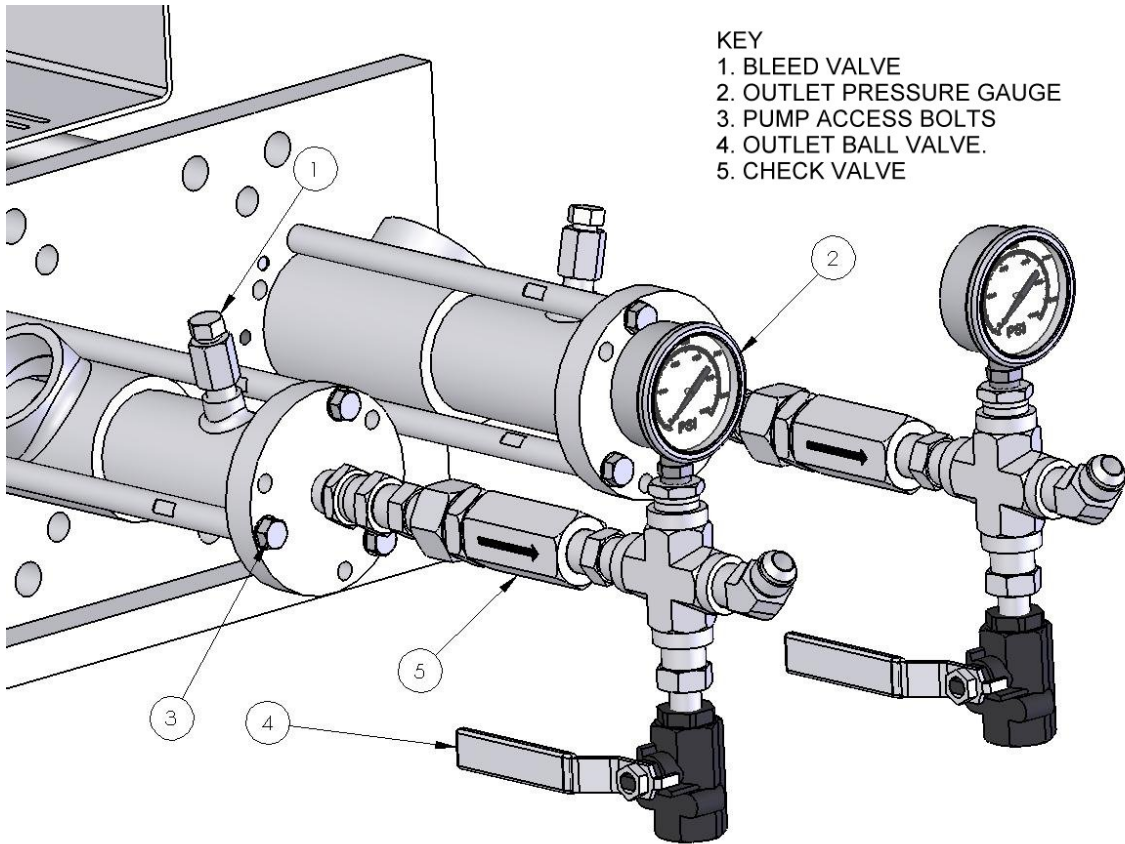

**Figure 1**

2. The position of the uni-directionally operated roller valve, (uni-dir), (fig 2, #2) is typically factory set at the proper position. If the meter has been disassembled or adjusted, the position of the valve may need to be reset. Set the position of this valve as follows:
  - 2.1. Disconnect the air line marked “seal check”. This should be the air line coming from the uni-dir valve. (With this line disconnected, the dispense valve will not open.)
  - 2.2. Set the air pressure regulator at 15-20 psi, (fig 3, #1 & #2).
  - 2.3. Input a start signal, (the machine should push both rods into the pumps and stop after about 1 1/2” of travel.)

- 2.4. Disconnect the air from the machine, (fig 3, #3).
- 2.5. This is the position where the uni-dir' valve should be actuated to open the dispense valve. If the valve is not already at this position, continue the following:
- 2.5.1. Loosen the two screws, (fig 2, #5) that hold the uni-dir' valve in place.
- 2.5.2. Slide the valve along the mounting slot until the valve roller is being actuated by the drive bar or valve actuator pin, (fig 2, #4), and tighten the two screws. ***(Be careful not to move the valve too close to the actuator as this will cause the hinged arm to fatigue and or break.)***
- 2.5.3. *Make sure the valve arm does not bind when the actuator travels on past the roller.*

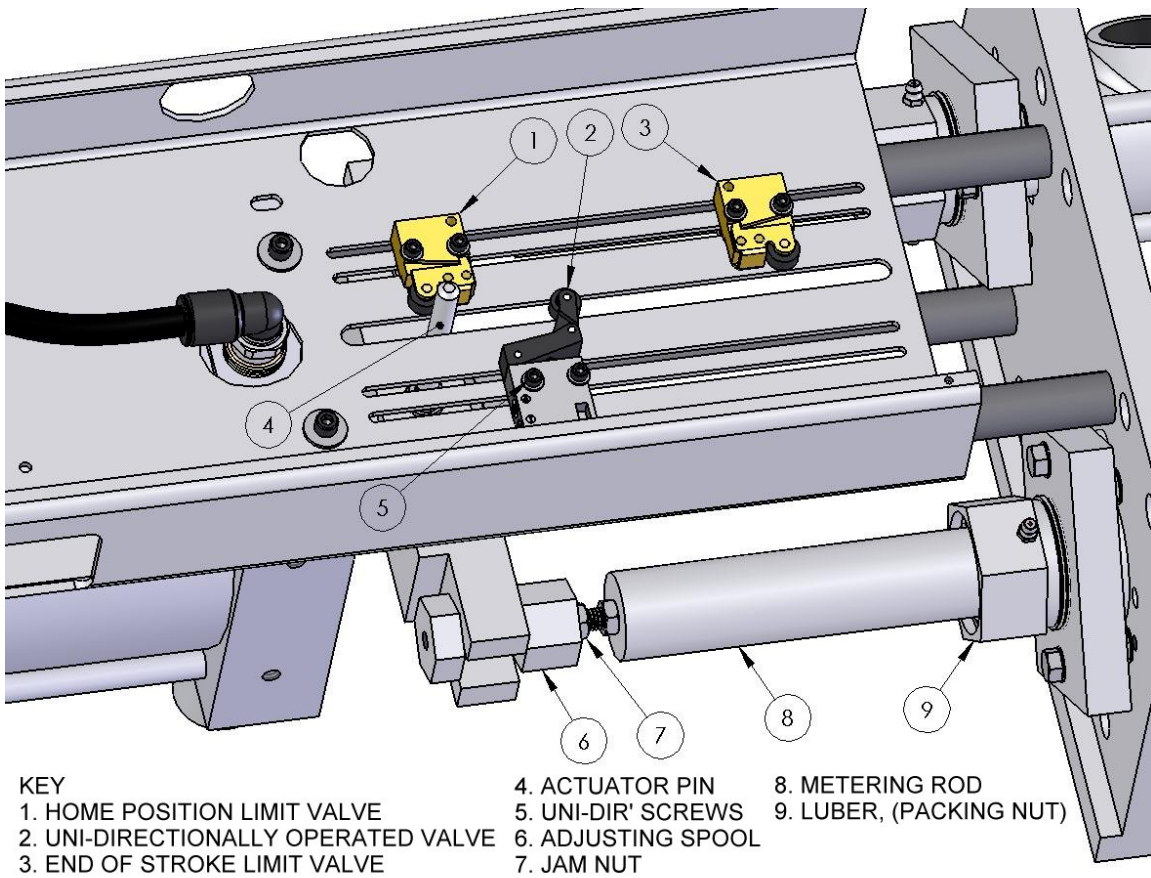

**Figure 2**

- 2.6. Reconnect the air and adjust the air pressure regulator, (fig 3, #1) at the desired setting/flow rate.

- 2.7. Watch the material coming out of the dispense valve/manifold at the beginning of each stroke. If one material lags behind the other, make sure all of the air is bled out of the pump that lags, (see step one).
- 2.8. If this has no effect, loosen the jam nut, (fig 2, #7) on the side that lags.
- 2.9. Turn the adjusting spool, (fig 2, #6) CCW to move the rod further into the pump ½ turn at a time.
- 2.10. Input a start signal and watch the start of each cycle in between each adjustment until both materials come out simultaneous. This will get the phasing very close. Excess difference of rod positions, (more than ½”) typically indicates air entrapment but also could be a worn pressure seal or malfunctioning check valve, (fig 1, #5), see the “pressure seal/check valve” test procedure in the manual.
  - 2.10.1. *If both material pressures go up just prior to dispensing, or the machine stops before reaching the uni-dir position, this would indicate that the uni-dir valve adjusted too far into the stroke, (pressure is being built prior to dispense valve opening).*
  - 2.10.2. *Adversely, if both pressures drop way off, (a small amount is somewhat typical) the uni-dir is opening the dispense valve too early, allowing the material to come out of the dispense valve before the metering rods have reached the pressure seals. Repeat steps 2.1-2.7.1.*

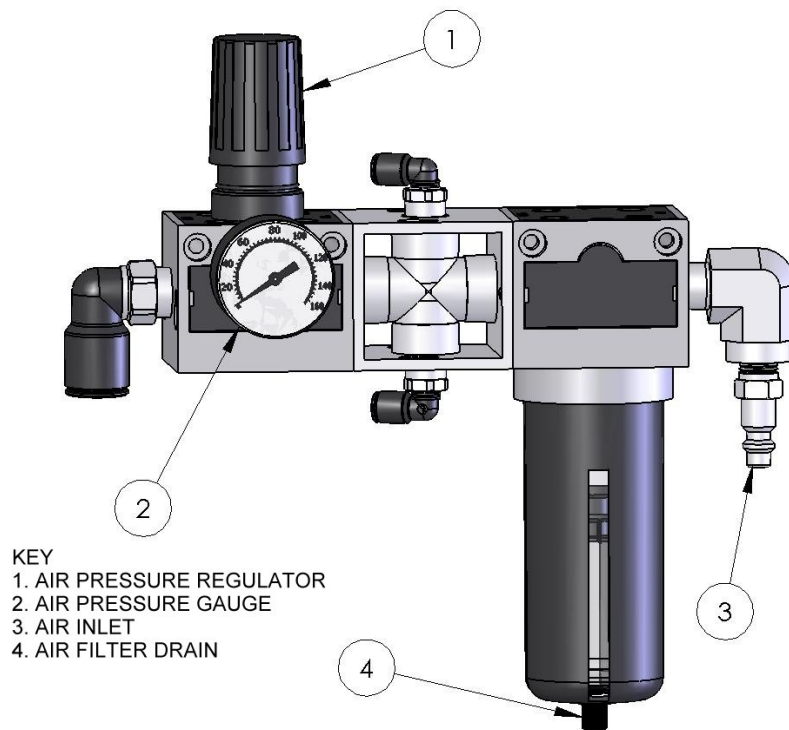

**Figure 3**

3. For fine-tuning of the phasing adjustment, complete the following:
  - 3.1. Attach the desired mixer and dispense until the mixer is full of material.
  - 3.2. Dispense a small amount of material a few times while watching the outlet pressure gauges, (fig 1, #2) at the beginning of each cycle. (The pressures may be different but should start rising together.)
  - 3.3. Adjust the lagging rod inwards as described in step 2 k-m until both pressures rise together. (Sometimes with materials of different colors, watching these materials go through the mixer will also be indicative of which material is leading/lagging and this may be an easier method to set the phasing.)
  - 3.4. To test phasing adjustment, dispense small 1 to 1-1/2 foot long strips of material onto some aluminum foil or similar substrate, (cardboard or paper may wick out the catalyst and affect the results.) A soft spot in the middle of this strip is indicative of a phasing problem. For real low viscosities, (little back pressure showing on the outlet pressure gauges) this also will help to determine which side is lagging.