

AUTOMATIC DUAL COMPONENT DISPENSE VALVE

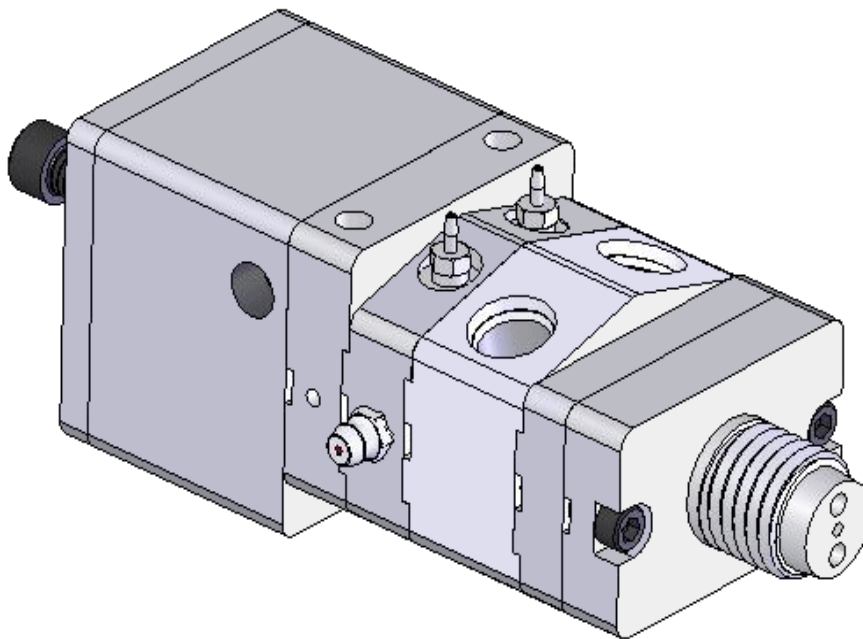

FEATURES AND BENEFITS

- Reliable, simple rugged valve
- Adjustable snuff-back and/or straight shut off
- Pressure lube pack for longer seal life
- Pneumatic operated/ air to open/close
- Quick, easy fixture mounted and/or hand-held
- No-drip reverse seating valve
- 1 cps to 1,000,000 cps materials
- Stainless steel optional
- Simple-modular design
- Replaceable manifold w/ purge

VALVE CROSS-SECTION

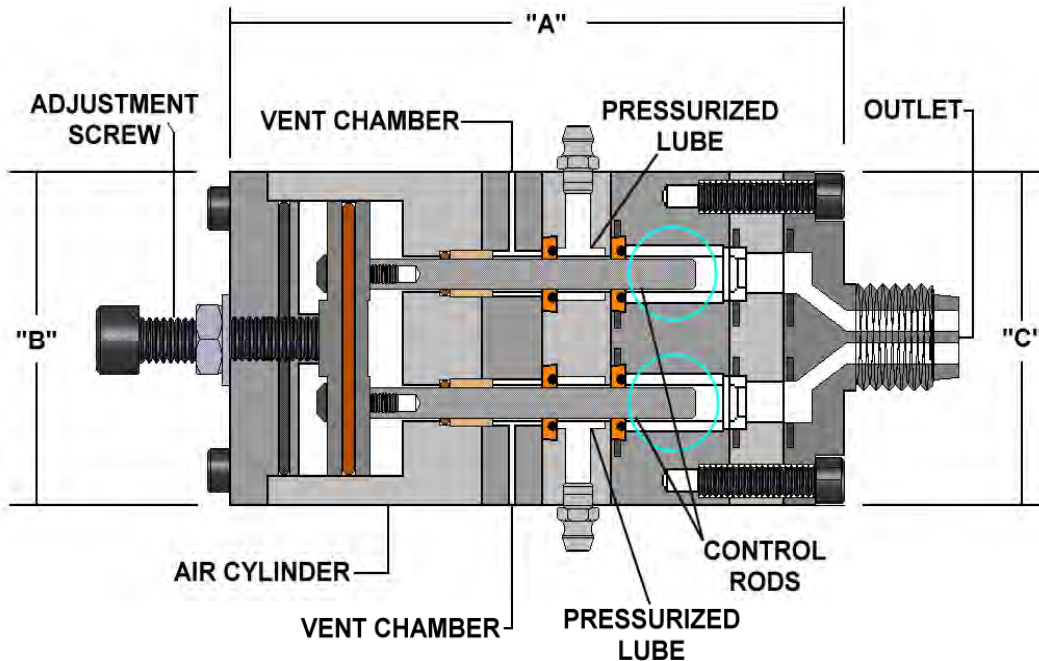

VALVE TECHNICAL DATA

DESCRIPTION	55216	55246
INLET PORT	9/16"-18 SAE	9/16"-18 SAE
OUTLET PORT	7/8"-9 Bell Mount	7/8"-9 Bell Mount
ROD DIAMETER	1/4"	1/4"
WORKING PRESSURE	2,500 psi	2,500 psi
SEALS/ O-RINGS	URETHANE, UHMW, EPDM, VITON, BUNA, & SILICONE	
A	7-3/8"	7-3/8"
B	2-1/4" x 2-1/4"	2-1/4" x 2-1/4"
C	1-1/2" x 2-1/4"	1-1/2" x 2-1/4"