

METERING & DISPENSING EQUIPMENT FOR THE PROFESSIONAL CONTRACTOR

PCH GMP-075 "BIG PRO"



APPLICATIONS

- **Joint Filling**
- **Concrete Restoration**
- **Large Joint Sealing**
- **Large Spall Repair**
- **Anchoring**
- **Floor Coating**

FEATURES AND BENEFITS

- **Portable, Reliable, Rugged Design**
- **Easy to Operate & Maintain**
- **Stainless Steel Construction**
- **Changeable Ratios**
- **9 Gallon Stainless Steel Tanks**
- **3/4 HP DC Drive Motor**
- **Automatic Dispense Manifold**
- **Electric/Pneumatic Powered**
- **Backed by AST Warranty**
- **Pumps Non-Abrasive Materials**
- **Fixed Ratios of 1:1 to 4:1**
- **Continuous Flow Up to 1.0 GPM**
- **Fluid Pressures Up to 750 PSI**
- **Viscosities Up to 10,000 CPS**
- **Variable Flow Rate**
- **Uses AST GMP Metering Pumps**

PRODUCT SPECIFICATIONS

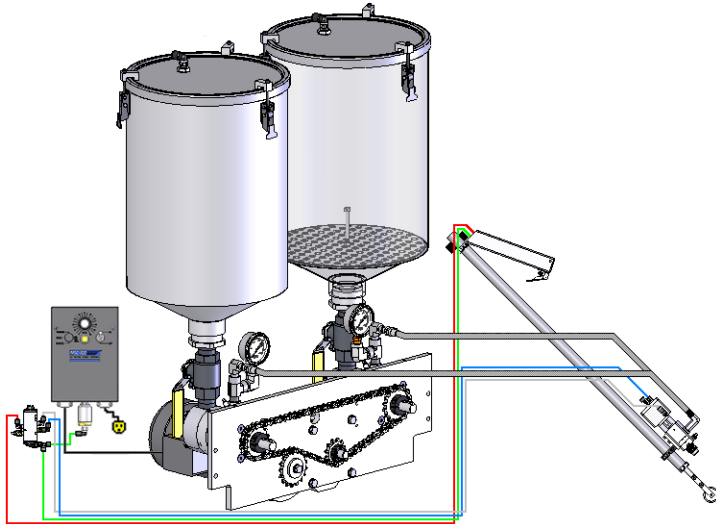

Applications for the "Big Pro using non-abrasive polyureas, epoxies and urethanes include:

- Large Joint Sealing
- Large Spall Repair
- Anchoring
- Joint Filling
- Concrete Restoration
- Floor Coating

MODEL	PCH GMP-075	FRAME	1½" powder coated tubular steel
MACHINE TYPE	Fixed ratio/metering/ dispensing GMP gear	AIR DRYER	Desiccant cartridge
CONTINUOUS OUTPUT	Up to 1.0 gallons per minute	GAUGES	(2) glycerin filled 600 psi
RATIO RANGE	1:1 to 4:1	STANDARD CONTROLS	On/Off; variable speed
VISCOSITY RANGE	100 CPS to 10,000 CPS	SERVICES REQUIRED	120 V. / 15 AH, 5 AMP 90 psi, 2 cfm
CONTAINERS	9 gallons each side, stainless steel, 16 gauge	APPLICATORS	AST hand held; manual dual port manifold
MOTOR	.75 HP DC, 90 volt	MIXER	Disposable, plastic, motionless
METERING PUMPS	(2) heavy duty AST GMP gearotor™	HOSES	Teflon core braided stainless steel 3/8" x 15'
DIMENSIONS	27" L x 36" W x 40" H 200 lbs. empty, shipping weight 250 lbs.	OPTIONS	Heated tanks Power inverter Generator mount Air purge Factory installed aspirator Head assembly

ADHESIVE SYSTEMS TECHNOLOGY CORP.
9000 Science Center Drive, New Hope, MN 55428
Phone: 763-592-2060 • Fax: 763-592-2075
www.ast-corp.net • ast@ast-corp.net