

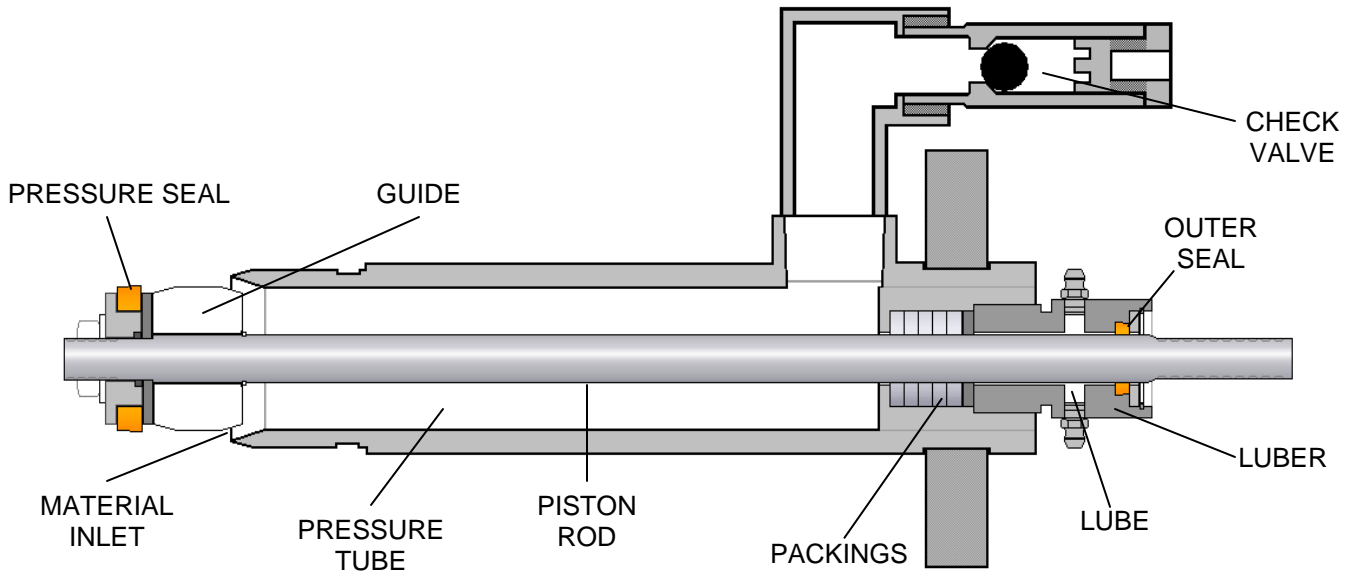

**ADHESIVE SYSTEMS
TECHNOLOGY CORP**

METER-MIX DISPENSE EQUIPMENT

BASIC CONCEPT OF CMP™ METER



CMP™ FEATURES:

- Positive displacement metering
- Modular concept to allow for system design and application
- Fixed ratio with quick ratio change in multiples from 1:1 to 4:1
- Power drive can be air, hydraulic or electric
- Low shear metering design
- Exclusive lube pack
- Interchangeable fluid section
- Ratio check and air purge valves
- Interphases with control panel or microprocessor

CMP™ BENEFITS:

- Precise ratios and metering
- Allows regulation of both fluid pressure and flow to application requirements
- Design capabilities enable use of a wide range of volumes and ratios (Ex: 5 cc to 1/2 gal per stroke)
- Enables system to handle shear sensitive materials (Ex: glass balloons)
- Quick material check and positive air removal
- Ideal for moisture sensitive materials
- Quick, easy and inexpensive to rebuild or replace
- Cycle rates adjustable up to 60 per minute

RECHARGING

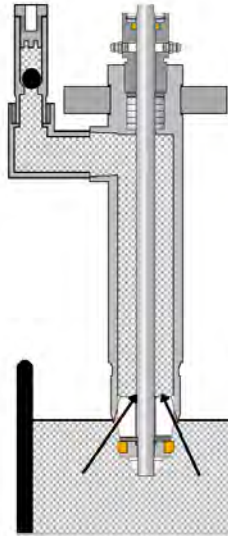

DISPENSING

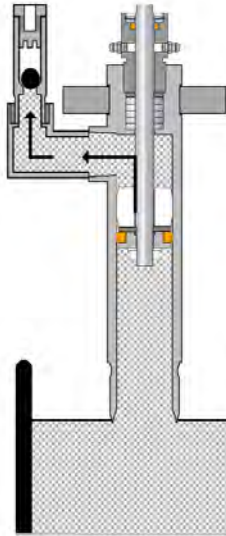

EXTENDING

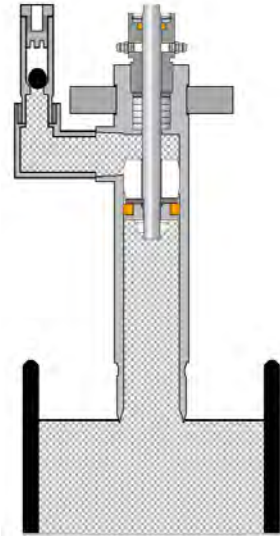

TYPICAL APPLICATIONS

SINGLE COMPONENT DISPENSING

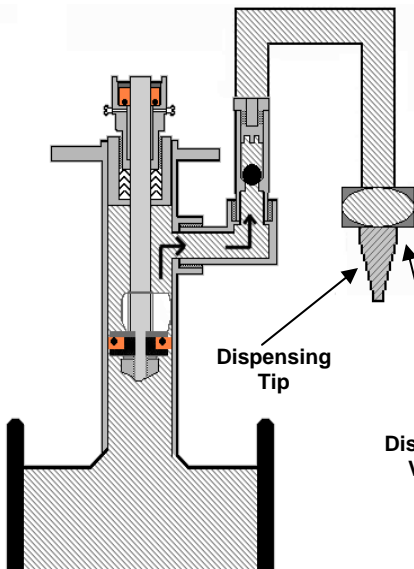

TWO COMPONENT DISPENSING & MIXING

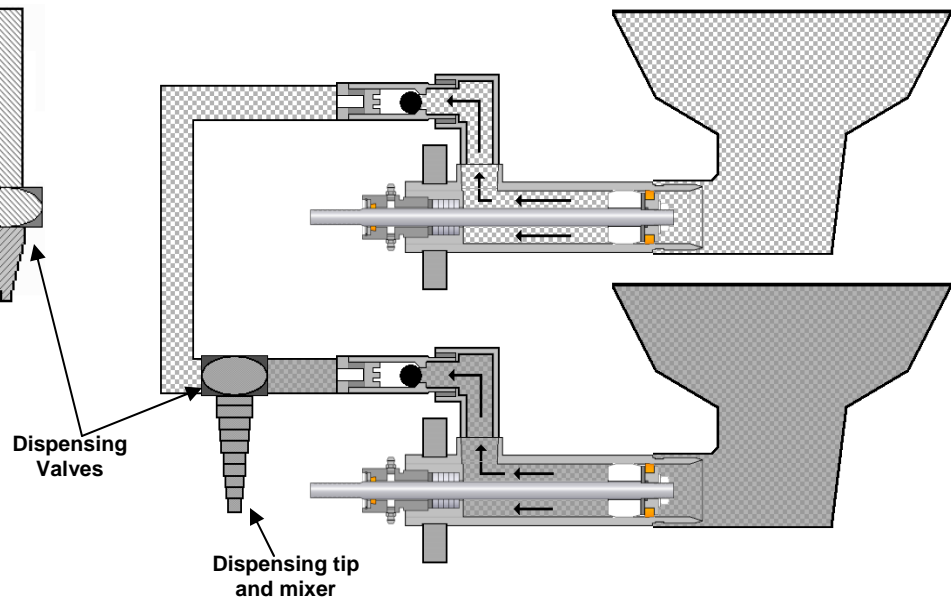

NOTE:

Meters may be ganged for multi component materials or application points if required.

A variety of dispense head valves and controls are available to fit specific tasks either on production line or for portable applications.

ADHESIVE SYSTEMS TECHNOLOGY CORP.
9000 Science Center Drive, New Hope, MN 55428
Phone: 763-592-2060 • Fax: 763-592-2075
www.ast-corp.net • ast@ast-corp.net